

Electric fuel contents gauge (float type)

Introduction

The electric fuel contents gauge system is supplied as a complete kit to be fitted into a Europa. The sender unit is fitted into the top of the fuel tank, and accessed through a hole cut into the port side headrest locker base panel. The probe of the sender contains eight switches which are activated by the float which runs up and down the probe. These switches are positioned to account for the irregular shape of the fuel tank, and so equal increments of fuel quantity are indicated. Installation can be made during the early stages of cockpit module preparation during the build (see Builders Manual page 11-4 figure 5), or later, when the cockpit module is installed. There are two different techniques involved in the initial preparation

1. Preparation where fuel tank is not yet installed

If your tank is already installed, skip this section and go straight to section 3.

Refer to the Builders Manual at page 11-4 (headrest storage area). Cut a 100mm (4") diameter hole through the port side headrest locker base plywood as shown in figure 1. Note that this is the plan view when looking **down** from the top, through the headrest locker opening.

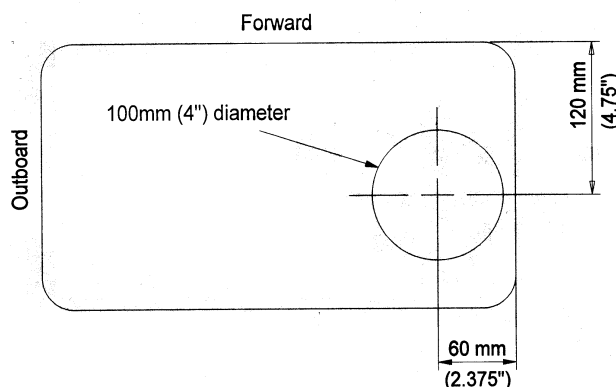

Fig 1. Dimensions of hole in port headrest base.

Install the plywood panel as described in the manual, except that you should trim away the two plies of 'bid' within the hole. Let the cloth overhang in the hole by approximately 10mm (3/8") at this stage, and cut and sand the edges after cure.

2. Marking the fuel tank for the probe hole

Firstly, identify the orientation of the tank - you will be fitting the sender into the port side, (which will become the "main" side, the starboard side will become the "reserve").

Running across the top of the tank there is a visible mould seam line. The centre of the hole will be 25mm (1") aft of this line, and 290mm (11 7/16") from the port edge. See figure 2.

Now skip section 3 and go straight to section 4.

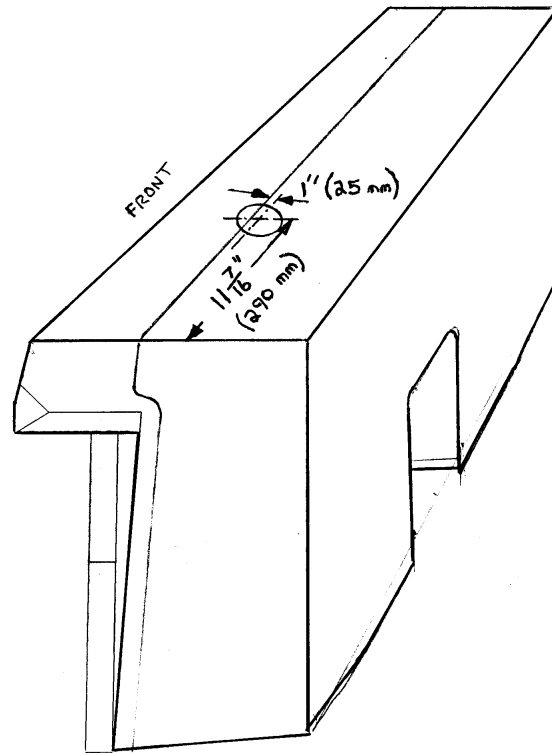

Fig 2. Position of fuel sender hole.

3. Cutting headrest locker base panel with tank installed

Using the dimensions shown in figure 1, mark out with a marker pen onto the upper surface of the headrest base panel.

Warning: *There is very little space between the underside of this panel and the top of the fuel tank, typically 3 to 7 mm (1/8" - 1/4").*

Drill a 10mm (3/8") diameter hole through the plywood just inside the marked 100mm (4") circle, taking extreme care not to make contact with the fuel tank!

Grind a hacksaw blade to narrow the width down to about half the original width. Do this on the end so that you will be cutting on the **pull** stroke. See figure 3.

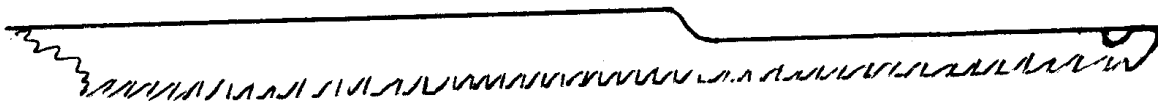

Fig 3. Ground hacksaw blade.



Hold the other end in a pad saw handle, or wrap the end in a suitable piece of cloth, and using the 10mm hole to gain entry, **carefully** cut out the 100mm (4”) circle, taking care not to mark the upper surface of the fuel tank. It is unlikely that you will cut through the tank accidentally, but any cuts or scars could lead to a possible stress raiser.

Alternatively you could chain drill the circle, but special care must be taken not to drill too deep. Some form of depth stop on the drill would be required to avoid the drill tip touching the fuel tank.

Looking into the headrest, through the hole in the headrest base panel, mark a line 25mm (1”) aft of the tank seam, and mark the lateral position to be central in relation to the base panel hole.

4. Cutting the hole in the tank

Before cutting the hole in the tank, there’s a bit of preparation to be done. The sender unit kit of parts includes the sender probe with a male threaded boss, and a matching flange with a female thread. Screw the two together firmly, referring to figure 4 for the flange orientation, and make a note of the positions of the five holes in the flange in relation to the exit point of the wires in the sender probe.

When installed the ideal orientation of the wires is towards the centre of the aircraft. (The routing of the wires will be inboard, and then forward and subsequently outboard behind the rear face of the seatback, where they will exit through a hole in the forward/outboard corner of the headrest, and route under the door sill to the instrument panel)

Take the alloy split ring and with suitable adhesive tape, stick it to the top of the fuel tank, centred on the previously marked lines, with the orientation of the five holes that will result in the sender wires exiting towards the aircraft centre.

Warning: *if you are fitting the fuel level sender to a tank which has fuel or fuel vapour in it, it is essential for safety that the tank is first emptied of all fuel, and subsequently purged with carbon dioxide or nitrogen to ensure that there is no chance of igniting the vapour.*

To cut the hole in the tank and not cause swarf to fall into it, you will need a small soldering iron, about 25 to 40 watts is recommended. Remove all traces of solder / flux from the tip and, once the iron has reached its maximum temperature, melt into the tank holding the iron as straight as possible, using the metal ring as a guide and cutting on the inside of the ring. Do not force your way around the hole, let the iron melt its way around with only light pressure. When you have nearly completed the circle, ensure that the disc which remains does not drop into the tank by holding it with pliers.

Carefully remove any stray “strands” of tank material with a sharp craft knife or scalpel, taking care not to mark the edge of the hole, which could cause stress raisers.

Wipe the top of the iron with a cloth, and melt down through the remaining five mounting screw holes; you will need several attempts for each hole, wiping off excess plastic in between each. Check that the AN525 bolts pass through each hole.



Remove the metal ring from the tank, and remove all traces of adhesive tape and molten plastic, ready for the next operation.

5. Anchor nut ring

Supplied in the kit are five fuel proof sealing anchor nuts part number NAS1473-A3, which are to be riveted to what will become the underside of the split ring, using TAPK33BS rivets. Using one of the AN525-10R16 bolts thread an anchor nut onto the bolt through one of the five holes in the split ring. You will notice that the captive nut within the fuel proof housing is able to “float”.

Position the anchor nut so as to align the two attachment holes radially around the split ring, and clamp it to the ring with locking pliers (or mole grips or similar). Check the centralization of the anchor nut by moving the AN525 bolt from side to side, aiming to get an equal amount of deflection in each direction. Adjust the anchor nut until this can be achieved.

Drill through one of the anchor nut lug holes with a 2.4mm (3/32”) drill, then countersink the hole in the split ring deep enough for the head of the pop rivet to sit flush, and set the rivet, ensuring that you have not forced the flange of the anchor nut away from the split ring, which would allow the rivet to swell in between the two parts.

Remove the pliers, and without moving the anchor nut drill through the other lug hole, repeating the drilling and riveting operations.

Repeat the above for the other anchor nuts.

6. Installing the threaded flange

Tie a loop of thin, strong thread around the split ring, diametrically opposite the split (fishing line works well). This is a safety line to prevent you from inadvertently losing the split ring assembly in the tank!

On an uninstalled tank the next operation is relatively easy, whereas on an installed tank you may come close to your dexterity and patience limits!

Twist the split ring to form a scroll shape to allow it to be screwed into the tank, with the anchor nuts at the bottom. Between the split ring and the tank, sandwich one of the rubber gaskets, with the second between the tank and the outer threaded flange - see figure 4.

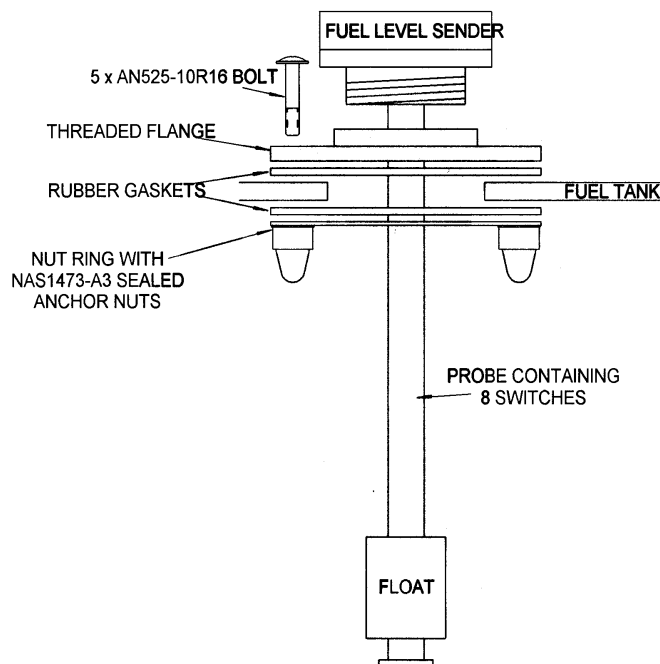

Fig 4. Assembly of sender to fuel tank.



Position the outer flange the way you noted earlier, so that the wires run towards the aircraft centreline.

Insert one of the AN525 bolts into the outer flange passing in turn through the rubber gasket, the split ring, the inner rubber gasket, and into the anchor nut. Engage the bolt into the anchor nut by a couple of turns. Repeat this procedure with the other four bolts.

Before you fully tighten the bolts, cut the safety thread and remove it. Tighten up the five bolts in stages until there is a firm pressure on the rubber gasket.

The sender unit can now be screwed into place. To check the seal of the flange, apply a solution of soapy water, and with all other openings capped off, apply lung pressure only, **don't use air pressure lines**, to pressurise the tank. Bubbles in the soapy water will indicate a leak. Tighten the bolts if required.

7. Electrical connection

The kit comes with a ready made wiring loom. This is to be connected according to the diagram in figure 5. The +ve connection might be most suitably connected to that which supplies the engine instruments.

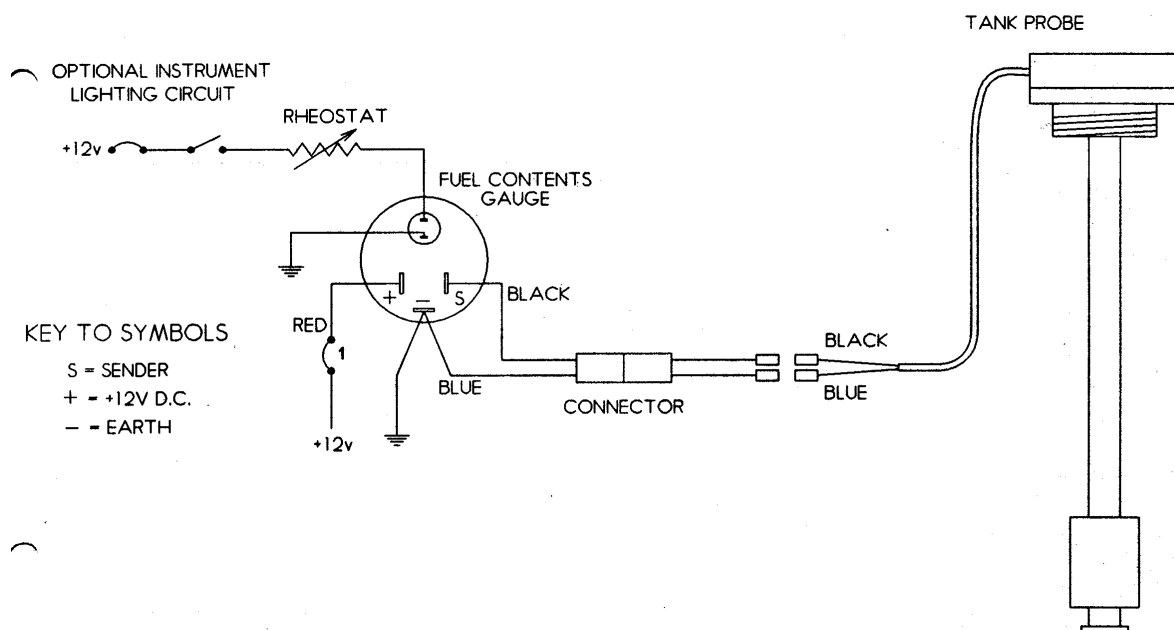

Fig 5. Electrical wiring diagram. Not to scale.



Cut a small hole through the base of the headrest, near to the front, outboard corner, for the wires and spade connectors of the loom to pass through. A dab of silicone here will prevent chafing of the wires.

8. Function check and calibration

Fill the fuel tank completely, but ensure that the filler neck has not also been filled. Check that the indicator reads full.

With the aircraft in the level attitude, drain the tank with the MAIN side selected and note the quantity of fuel drained each time the indicator trips down a 1/8 increment. Keep a record of the calibration for later reference.

Make sure that the indicator reads zero at the same time, or slightly before the MAIN side of the tank empties.

9. Headrest base panel cover

To prevent small items from falling through the hole in the headrest locker base, fit a cover which may be secured with dabs of silicone or similar. Keep the cut out for the wire to pass through as small as possible.

You may need access to the sender again at some point in the future, so don't fit the cover too permanently.

10. Fuel sight gauge

Because it is not possible to see the fuel quantity in the tank directly it is important that some form of sight gauge is retained for pre-flight verification. A sight gauge, using the 6mm bore polyurethane tubing supplied with the fuselage kit, could be routed up the seat back bulkhead between the occupants having emerged from a hole at the corner of the centre bulkhead and the port side of the centre tunnel. Routing to run into the starboard headrest and then out the other side to be connected to the vent tube would complete the sight gauge.

Although the last 5 - 6 cm (2") or so of the sight gauge would not be visible, this would only prevent you seeing the last 2 or 3 litres. Anything less than 10 litres should be considered insufficient for flight, so this would be acceptable.

Calibration of the sight gauge should be carried out according to the instructions in the Build Manual.