

34. Door latches (post Mod 67)

Overview

The door latch system for the Europa's gull wing type doors works on the 'shoot-bolt' principle. As the door latch is operated to its closed position tapered pins emerge from the door, one each fore and aft, locating into a hole in the door frame, the taper of the pin pulling the door against a rubber seal. Figure 1 below should clarify the principle of operation.

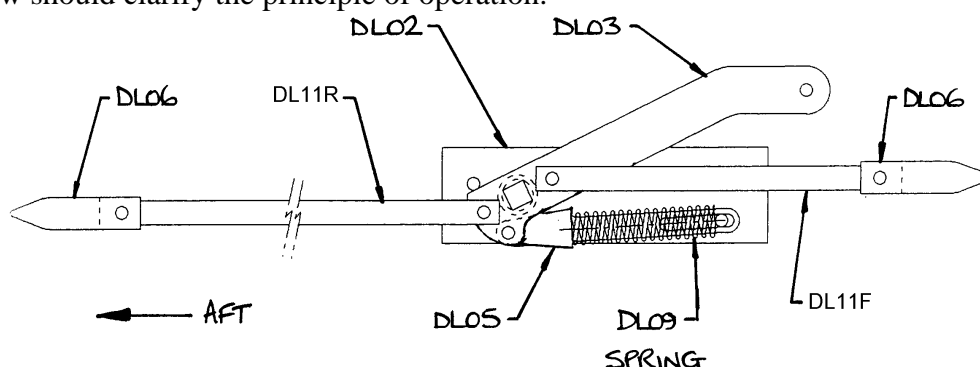

Fig 1. General arrangement of door latch components.

Step 1

Preparation of parts

To enable an easy understanding of the door latch mechanism, and to check all the parts fit together properly it is advisable to assemble the components on the bench initially then later install them into the door. Before the mechanism can be built up, however, some fettling is required on certain parts. Apart from the usual cleaning up of the edges of punched parts the following is required:-

- * The outer and inner operating handles, DL01 and DL03 respectively, have square holes in them which locate on and drive the spindle DL04. The square holes are sized to be a press fit onto the spindle. Any slackness here will result in sloppy handles which will rattle and wear even looser. Over sized DL04 spindles are available if you do end up with slop.
- * The inner handle DL03 requires a joggle to be bent into it to clear it from the side screen when installed. To avoid bending too sharp a radius, clamp the handle in a vice with a bar of approximately 25 mm (1") in diameter. Pull the handle against it until you reach the required bend then re-position it for the other bend to get the joggle required.

Remember! Crank one the opposite way to the other. The handles should be handed port and starboard.

- * Open up the two holes in DL03 to which the push-rods attach to 5 mm diameter so that the bolt will be free to rotate in them.



- * To finish off the inner handle an end knob can be attached using the hole in its end. The knob can be made from wood quite easily. A door handle guard will be fitted later, and the handle and knob should be arranged not to project inwards beyond the inner face of the door frame.
- * The outer handle is a streamlined shape. A wooden grip should be made which will then be bonded to the plate. This grip should be made with a cavity in the back of it to clear the anchor nut of the outer handle. Attach an MS21047-3 anchor nut across the square hole of the outer handles using TAPK36BS rivets, having countersunk the back face first. Make sure that you attach the anchor nuts on opposite sides to end up with a handle for each door.

The push-rods DL11F and DL11R, two short and two long, are made up from the 10mm x 5mm rectangular section aluminium bar. Cut these push-rods to length and make the ends according to the drawing in figure 2. You will need to file down the thickness of the pushrods at one end where you will fit a single leg anchor nut (leaving it full thickness would result in the pushrod fouling the inside of the door).

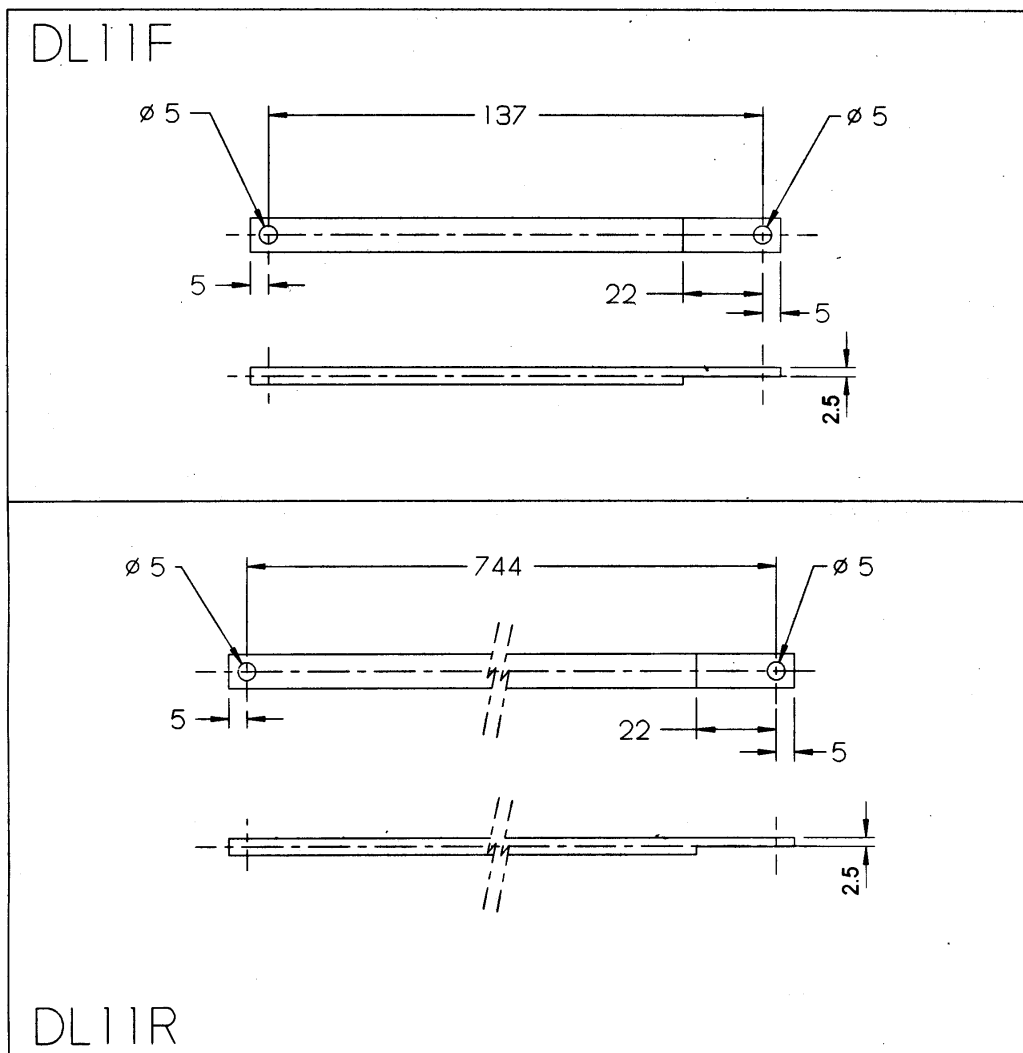

Fig 2. Fore and aft push-rods.

Attach one MS21051-3 anchor nut to the filed down end of each push-rod using two TAPK 36BS rivets. See figure 3. Countersink the 2.4mm rivet holes in the unfiled face of the push-rod first. You can do an acceptable countersink by using a drill of around 5mm (3/16") diameter.

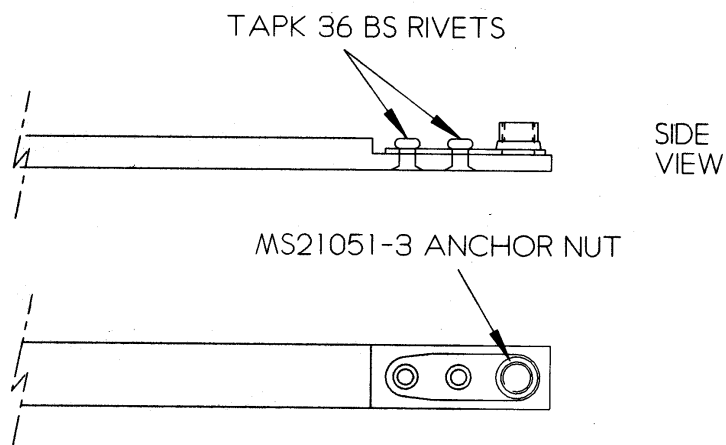

Fig 3. Attachment of anchor nut to push rod.

Having made the push-rods DL11F and DL11R attach the shoot-bolts DL06 using the EUR007 roll-pins, filing the ends so they are not proud of the shoot-bolt's surface. The roll pin should grip in the shoot-bolt and be free to rotate in the push-rod. Lubricate the joints with grease.

Drill holes (3 - 5 mm diameter) in the plates of DL02P and DL02S spaced every 10 - 15 mm (3/8" - 5/8") approximately, but avoiding the weldments by at least 15 mm to avoid weakening them, to provide a key for the adhesive.

Note: Check that the ends of the tube through the plates are parallel to the plate and file off the minimum amount of material as required to bring them parallel. Ensure also that the cylindrical part of the shaft DL04 is just longer than the tube to enable both handles to be bolted tight without jamming.

With all the cutting and filing complete the basic mechanism can be bench assembled but first carry out the following steps.

Step 2

Latch cover plates

Later you'll be making a cut out in the door's inner skin to enable installation of the latch mechanism. This weakens the door frame so, to return it to its original stiffness, a cover plate will need to be attached.

The cover is a pre-moulded part (F33P and F33S) which will be bonded to the inner skin over the cut out.



Step 3

Cut outs

Mark out and cut out the inside skin as shown in figure 4 for access into the door for the latch mechanism. The idea here is to remove as little material as possible to retain as much of the door's stiffness as possible.

Covering the working area with masking tape makes marking out easier.

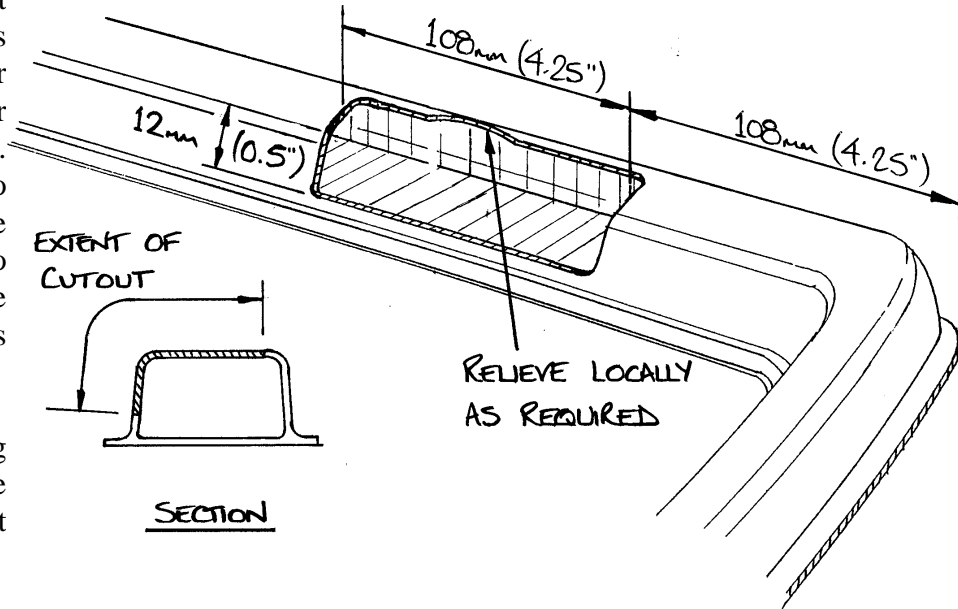

Fig 4. Cut-out dimensions.

Mark out and drill a 16 mm (5/8") diameter hole in the outer skin for the latch plate's tube.

Use a hole saw, not a conventional drill which will snatch, or simply drill a small hole and file it out to the correct size. See figure 5.

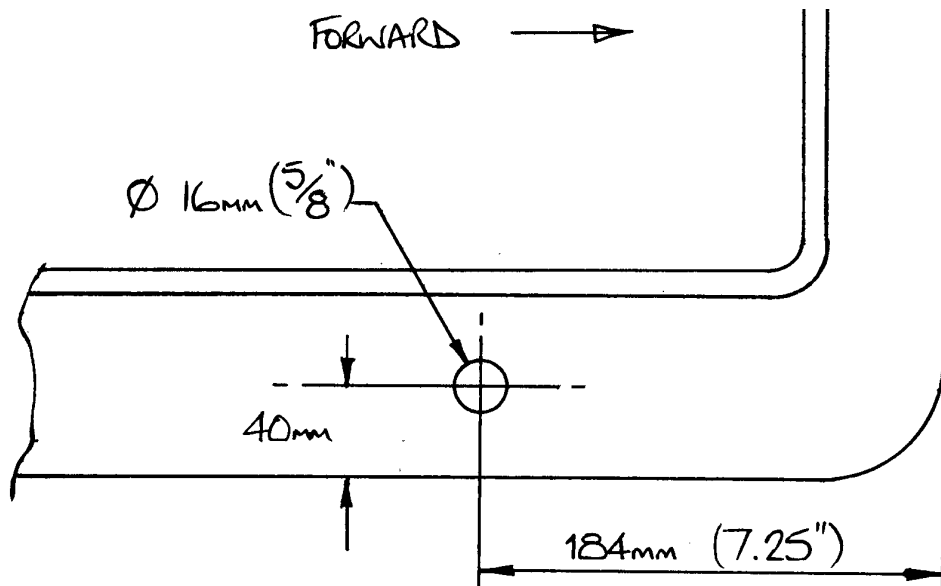

Fig 5. Forward lower portion of door.

Step 4

Mark out and make the holes for the shoot bolt guides DL07 in the forward and aft parts of the inside skin as detailed in figures 6 and 7.

File the holes until the guides are an easy fit and allow a little movement for alignment.

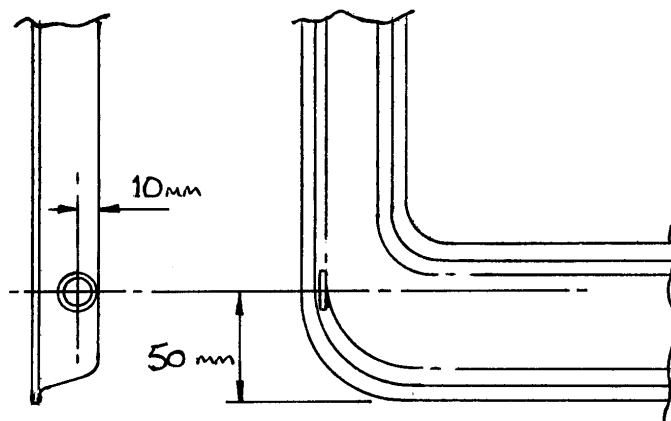

Fig 6. Forward shoot bolt guide location

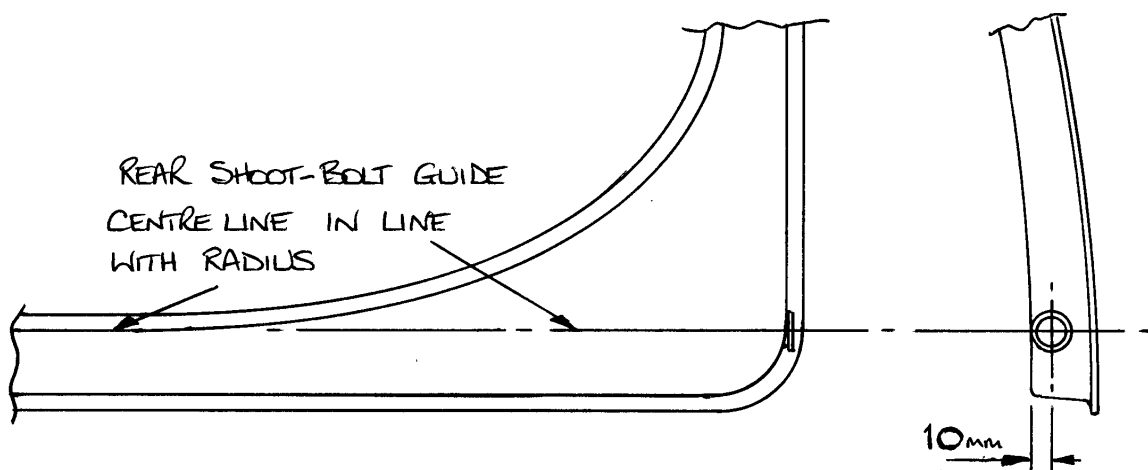

Fig 7. Aft shoot-bolt guide location.

Step 5

Bench assembly.

Referring to the exploded diagram in figure 8, select the base plate DL02P or DL02S depending on which side latch assembly you wish to do.

Bend the plate slightly to conform with the curve of the door's outer skin and ensure that a small amount of the tube protrudes through to the outside.



Using an AN3-5A bolt attach the spring guide DL05 to the handle DL03 with an AN960-10L washer between them. The spring guide should be on the opposite side to the handle's joggle and the bolt installed through the spring guide first. Fasten the bolt with an MS21042-3 nut with another AN960-10L washer under it. Tighten the nut fully then back it off sufficiently to allow the bolt to act as a pivot.

Place the spacer OR9 onto the threaded shaft of DL02. Slide the spring DL09 onto the spring guide DL05 and, pulling the spring back, place the guide's slot onto the threaded shaft. Retain it with an MS21042-3 nut, tightening it sufficiently without clamping the guide. The spring rests against both the spacer and the nut.

Insert the shaft with the squares milled at each end (DL04) into the plate's tube and attach the inner handle to it. Fit the outer handle DL01 to the opposite side then fasten the assembly together with an AN3-12A bolt with an AN960-10 thick washer under its head.

The basic mechanism can now be operated. You'll see how the spring acts to keep the handle at one extreme of travel or the other.

Remove the outer handle and try the assembled mechanism in the door to check for general fit and make any adjustments required. Check that full forward and aft movement can be achieved without interference between the handles and door skins.

Next, disassemble the mechanism ready for installation, leaving the inner handle and spring guide attached to the plate, but don't lose any of the remaining bits!

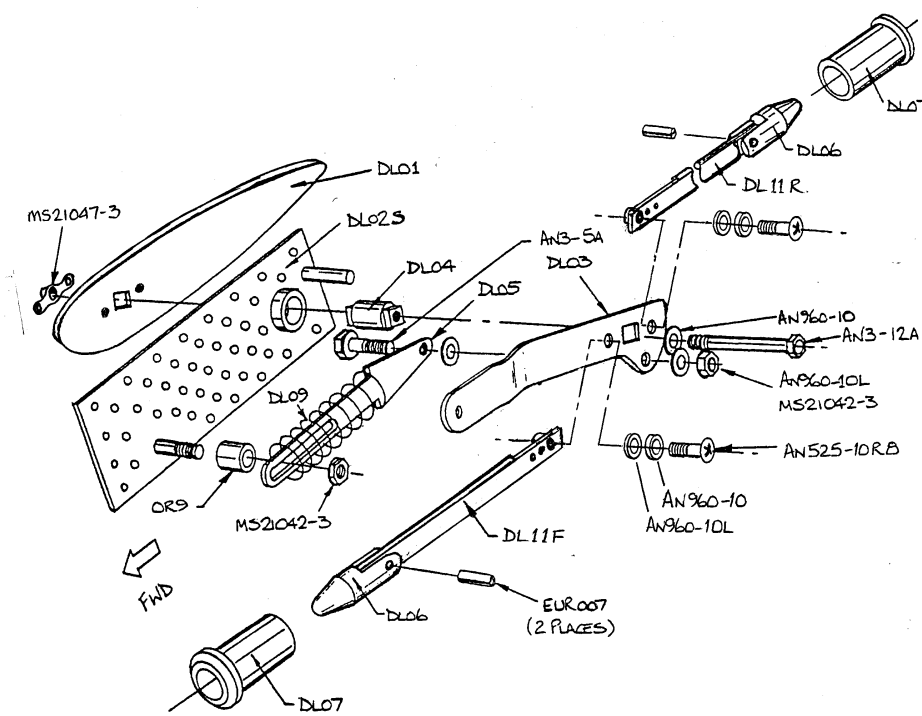

Fig 8. Exploded view of door latch components. (Stbd shown)



Step 6

Plate installation

Scuff sand the inside of the door's outer skin in the cut-out area and scuff the back of the plate DL02.

Mix some Araldite 420 adhesive, then mix some flox in with it to prevent it being too runny and coat the back of the plate with the adhesive. Squidge the plate into place allowing the adhesive to ooze through the holes and remove the excess. Make sure that the attached handle and spring guide don't prevent the plate sitting in properly or get covered in adhesive.

Align the plate squarely fore and aft and prop the door up so the plate is horizontal and will not move during cure.

Step 7

Shoot bolt guide installation

After the adhesive attaching the plate has fully cured re-assemble the latch mechanism in the door and install the push-rods through the fore and aft guide holes. Note that the long rear push rod will require to be curved but may still rub a little against the inner skin. Carefully bend this push-rod in the correct plane relative to the end slot as required to minimise the contact.

Attach the push-rods to the inner handle using an AN525-10R8 bolt in each case, with both an AN960-10 thick and an AN960-10L thin washer under the head. After tightening the bolt, back it off about $\frac{1}{4}$ turn to allow the bolt to act as a pivot.

In the unlatched position the dimension between the ends of the shoot bolts would be 952mm.

With the door latch still in its unlatched position slide the shoot bolt guides DL07 over the shoot-bolts and push them into the door.

Bond the guides into place with a mix of Araldite 420 and flox, using the retracted shoot bolts as locating aids. Ensure that the shoot bolt guides are set parallel to the line of the bottom of the door and that the mechanism isn't jammed then leave to cure.

Step 8

Fitting latch cover mouldings / latch guards

Trim the cover mouldings (which incorporate the latch guards) to the dimensions shown in figure 9 and cut back the area where the inner handle runs to clear it over its full range. To attain maximum stiffness around the cut-out it is necessary to bond the cover to the door's inner skin. It is advisable to leave this operation until the doors have been fitted in case access to the mechanism is required at this stage.

When you are ready to attach the cover, scuff sand the door's inner skin and the inside of the cover where they will be in contact with each other then bond it in position using Araldite 420 adhesive.

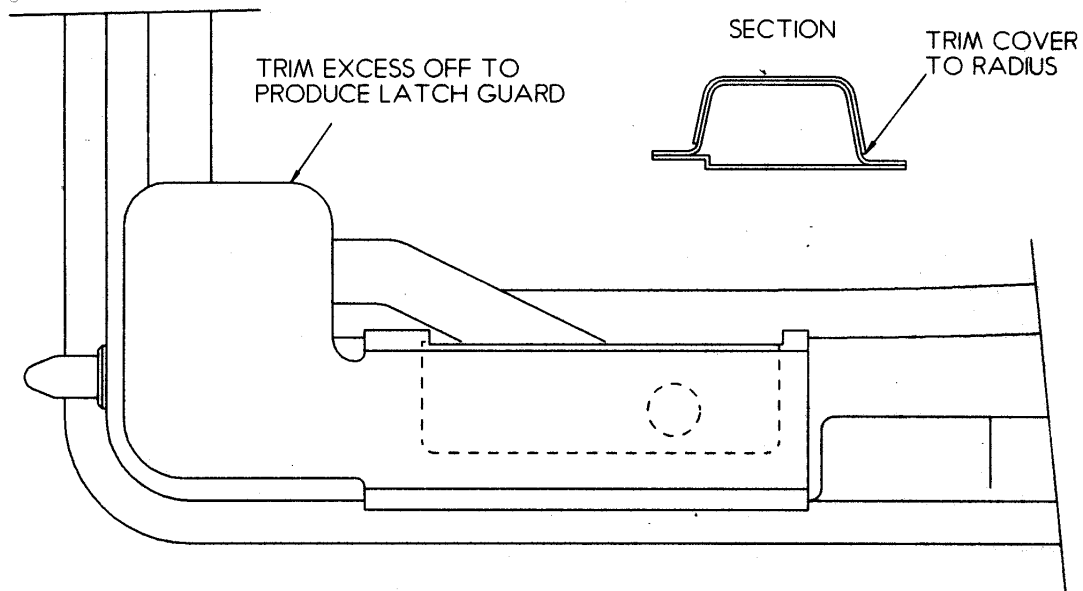

Fig 9. Latch mechanism cover plate.