

---

## 32M. Sternpost, rudder & tailwheel

---

### Overview

The sternpost, which was temporarily fitted earlier in the build process, will now be fitted permanently. The rudder is attached to the fin via three hinges using bolts and so is removable as required. The tailwheel is fitted to the lower rear fuselage, and is driven from the rudder.

### Comm radio antenna

The suggested position for the comm antenna is on the inside of the fin's port side rear flange. A dipole type of antenna, made with 10-16 mm (3/8"-5/8") wide copper tape can be fitted here once the sternpost has been permanently attached; however, it would be sensible to make arrangements for installing the antenna cable into the fuselage beforehand.

The total length of the fitted antenna will be approximately 1m (40") long and the cable attaches at its centre.

Drill a hole, large enough for the cable to pass through, in the rear bulkhead, and in the sternpost approximately 53 cm (21") below the fin top on the port side. Provision to support the cable between the rear bulkhead and the fin trailing edge could be added now. Details of the antenna may be found in Annex C.

### Sternpost and ribs installation

Installed into the fin are three ribs which bond to the sternpost. These are all to be bonded in together in one operation.

To hold everything in place whilst the adhesive is curing clecos or rivets are used; the sternpost has already been prepared for these.

It is very unlikely at this stage that, when viewed from the rear, the flanges of the fin and fuselage lower mouldings will be straight from base to tip. However it is important that they are straight, so before further work is done, some support must be provided.

Straight edges of seasoned timber, or even metal box section, approximately 25 mm x 25 mm (1" x 1"), should be temporarily bonded to the outsides of the flanges to keep them absolutely straight.

Position the straight edges so that clecos or rivets can still be inserted into the holes in the flanges to hold the sternpost in position during bonding.

Using several small dabs of bondo will ensure good adhesion but enable their removal with a sharp tap. Hold the straight edges to the flanges with clamps until the bondo has cured.



Referring to figure 1, mark the fin where the rib trailing edges will be, then using a square aligned with the fin rear edge, mark the inside skin with a reference mark further forward so that the ribs can be properly aligned.

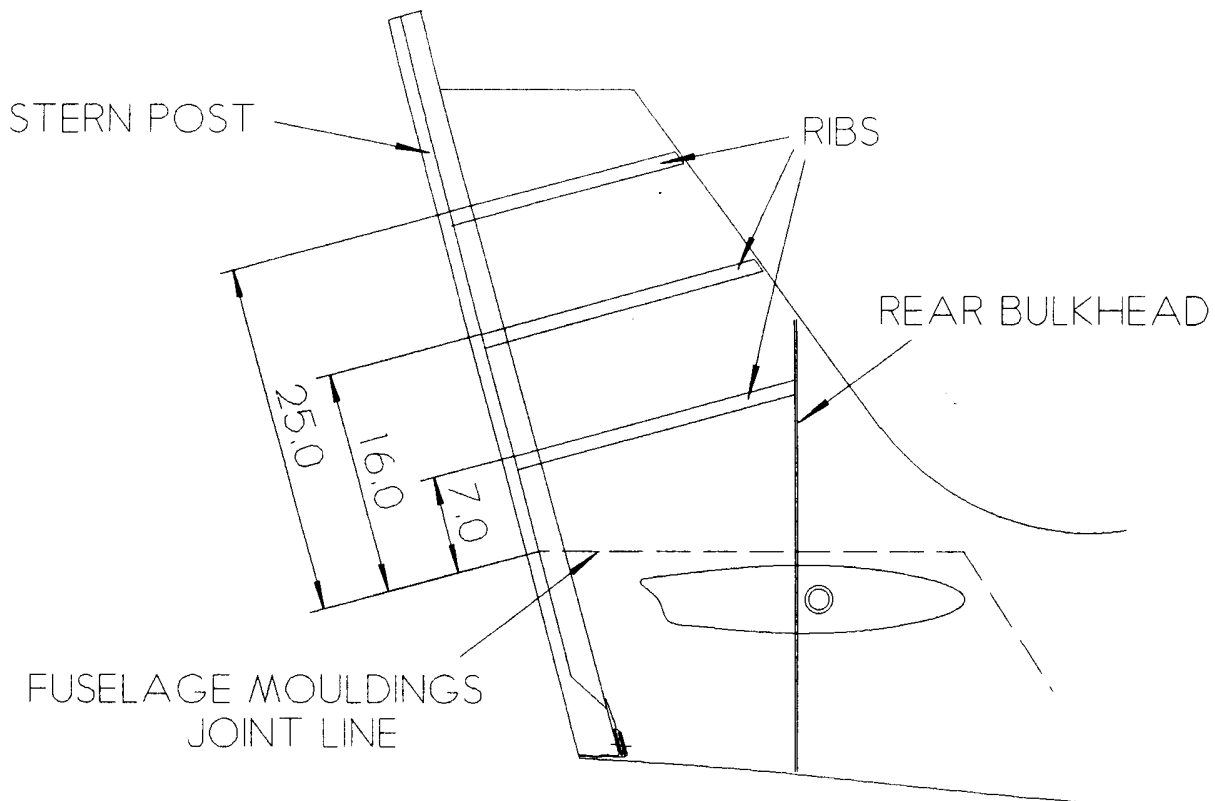

*Fig 1. Position of ribs in fin.*

Transfer the trailing edge marks onto the sternpost then drill and cleco the lower rib to it.

Cleco the sternpost in place in the rear fuselage to check that the rib fits correctly. Carefully drill through the fin skin into the rib flange each side for two or three clecos then repeat the exercise for the upper two ribs. Check that all three ribs and the sternpost fit together properly before the bonding operation, then separate the parts.

### **Bonding in sternpost and ribs**

Prepare all bonding areas by scuff sanding and cleaning the rib flanges, fin inside skin and the sternpost.

Spring the fin skins apart sufficiently so that you can insert the ribs with adhesive on their flanges and not wipe it off in the process. Wedge pieces of foam or wood to hold it like this until ribs are in place.

Using Redux 420 mixed with sufficient flox to stop it from slumping, coat the rib flanges which will contact the fin skins. Install them one at a time, clecoing or riveting them to one side only for now. Next coat the rib rear flanges and the sternpost flanges over their full length and carefully install the sternpost, removing the spacers springing the fin skins apart, then cleco or rivet it to one side.

Cleco or rivet the sternpost to the ribs, checking that the adhesive bond covers the entire rib flange by viewing through the sternpost. Cleco or rivet also the ribs to the opposite skin, then allow the assembly to cure before cracking off the straight edges and remaining clecos.

The port side of the fin sternpost needs to be trimmed so that it is in line with the edge of the foam core in the fin skin - see figure 2. If you don't do this you will be left with a gap between the sternpost flange and the fin flange. If you fill it with adhesive the flange will be excessively thick.

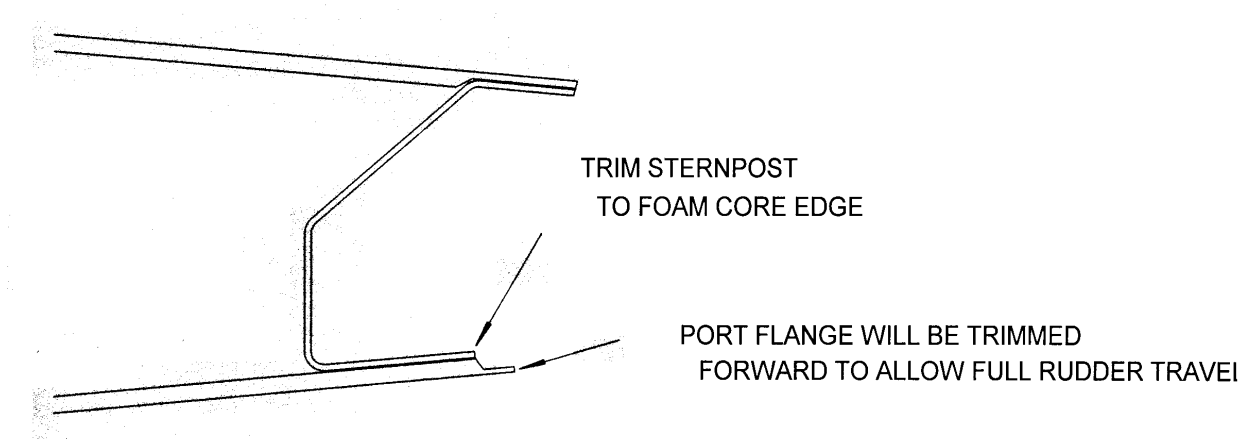

### Pressure equalisation holes

Drill three 1/8" holes through the sternpost into the fin, one above each rib, to enable pressure equalisation at altitude.

### Fin tip

The fin tip moulding can be fitted now so trim the top of the sternpost to allow this. Scuff sand the bonding areas of the tip moulding, fin skins and the sternpost flanges. Bond the tip moulding in place using the joggle to locate it correctly. Allow to cure.



## Rudder attachment

Mark out and drill the rudder hinges, with 3.3 mm (1/8") holes initially for clecos, according to figure 3.

Hold the rudder in place against the fin and mark the positions for the rudder hinges on the fin's starboard flange. File the flange away locally to allow clearance for the hinge pivot and then, with the rudder again in position with the fin drill through the flange with a 3.3 mm drill using the holes in the hinge as a guide. Mount the rudder to the fin with a cleco in each hinge.

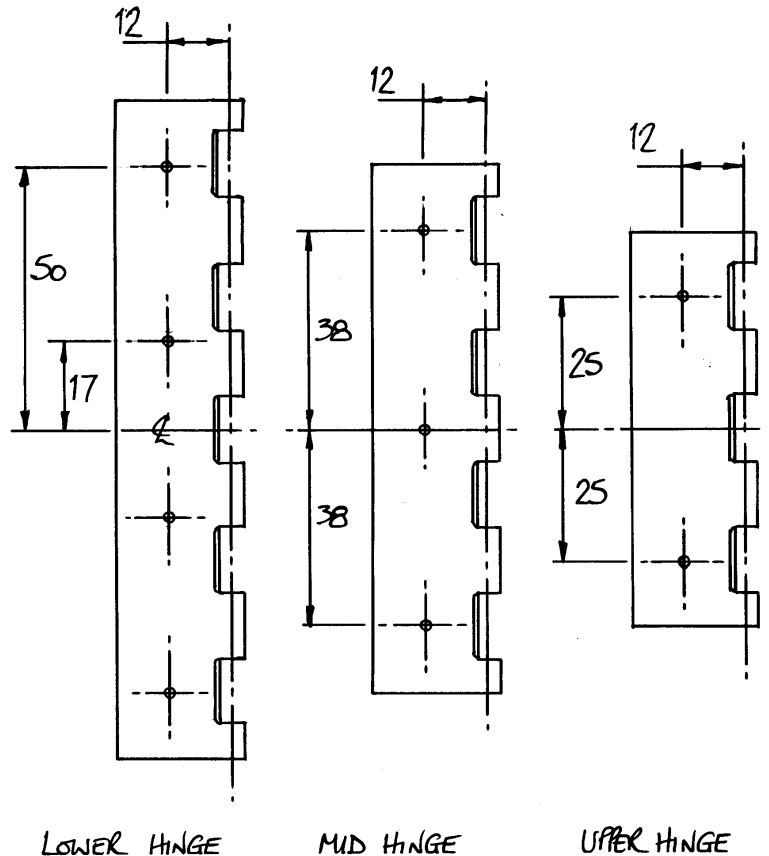

Fig 3. Rudder hinge bolt attachment hole locations.

The rudder will be free to pivot fully to starboard but the port flange of the fin and fuselage will require trimming forwards to enable the full  $30^{\circ}$  ( $+2^{\circ}$   $-0^{\circ}$ ) of rudder movement required to port.

As the rudder hinge line is angled to the vertical, the rudder will rise relative to the fin as it rotates to port and the leading edge portion of the rudder tip will require sanding to provide clearance for the rudder under the fin tip shroud. This reshaping will remove the skin locally and reveal the foam core. Sand sufficient material away for clearance allowing for 2 plies of 'bid', filler, and paint, then round off any resulting sharp edges to enable the cloth to cover the exposed foam easily.

Once you have checked that the required rudder movement can be achieved, with additional clearance, scuff sand the skin surrounding the exposed foam at the tip of the rudder then layup 2 plies of 'bid' over it, lapping about 1 cm ( $1/2$ "") onto the skin all around.

Whilst you are doing this layup, for hinge reinforcement, lay 2 plies of 'bid' at  $\pm 45^{\circ}$  locally where the hinges attach, each ply being 50 mm (2") longer than each hinge and running from the flange and onto the sternpost face at least 25 mm (1").

When you are happy with the rudder's position on the fin and  $30^{\circ}$   $+2^{\circ}/-0^{\circ}$  of movement is achievable port and starboard, enlarge the holes for the mounting screws with a 4.8 mm drill through both fin flange and hinge.

Remove the rudder and attach MS21047-3 anchor nuts to the hinge with TAPK 33BS rivets, countersinking the hinge to allow the rivets to be flush. AN525-10R8 bolts can now be used to attach the rudder except for the lower hinge which requires the slightly longer AN525-10R10 bolts.

Now put the tailplanes in place and hold the control column fully forward. Operating the rudder will cause it to contact the anti-servo tabs so material will need removing from their inboard trailing edge corner. Sand the tabs until you have about 6 mm (1/4") of clearance between the tab root and the rudder when the rudder is at its maximum deflection. If you have exposed the tab's foam core in obtaining the clearance, dig out the foam to a depth of about 6 mm (1/4") and fill the cavity with floc to tie the top and bottom skins back together.

## Drainage holes

To ensure that no water can collect in the bottom of the fuselage it is necessary to drill drainage holes. Two holes will be required - one immediately in front of the fin sternpost, and one in front of the rear bulkhead. The holes should be 1/4" diameter, and the exposed foam edges should be sealed with floc to prevent water ingress between the fuselage skins.

## Tailwheel

Fit the tailwheel spring through the hole in the sternpost and install an AN5-21A bolt through the mounting pad with an AN960-516 washer under the head from the bottom, securing it with an MS21042-5 stiffnut and another AN960-516 washer - see figure 4. Using Araldite 420, bond the spring to the sternpost where it passes through the 23 mm (7/8") diameter hole.

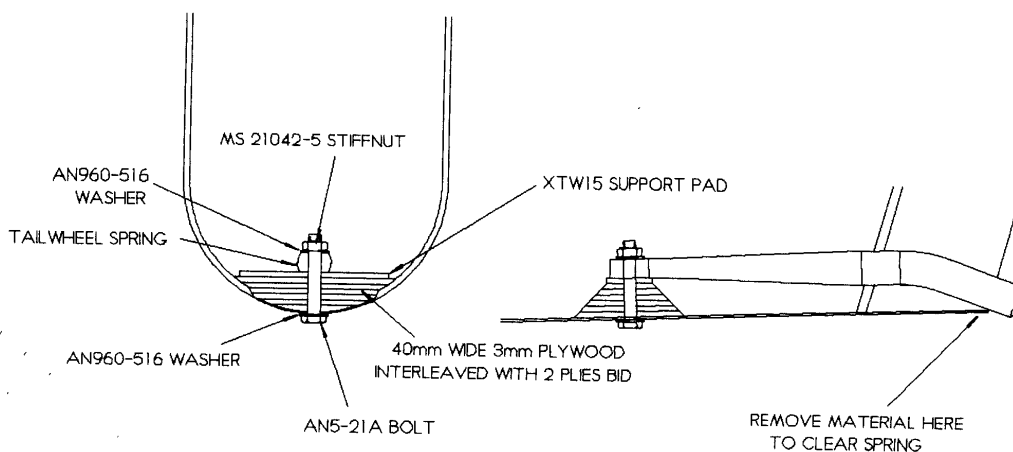

*Fig 4. Forward mounting of tailwheel spring.*

The tailwheel is supplied complete with bushes already installed and reamed. It may be necessary, before installing the fork onto the spring rod, to clean up the pivot shaft and thread, as scale may have formed on it during the hardening process.



Slide the tailwheel fork onto the spring rod, then secure it with an AN310-8 castle nut and EUR 036 washer. Tighten the nut sufficiently only to eliminate play, but still allowing the fork to pivot. A split pin is required to lock the nut, so using a 3.3 mm (1/8") drill bit, drill through the threaded portion of the rod between two of the nut's castellations. Take care with your aim to emerge the other side between castellations also. The spring rod is made from hardened steel which will make drilling quite tough. A new masonry bit is recommended for this operation.

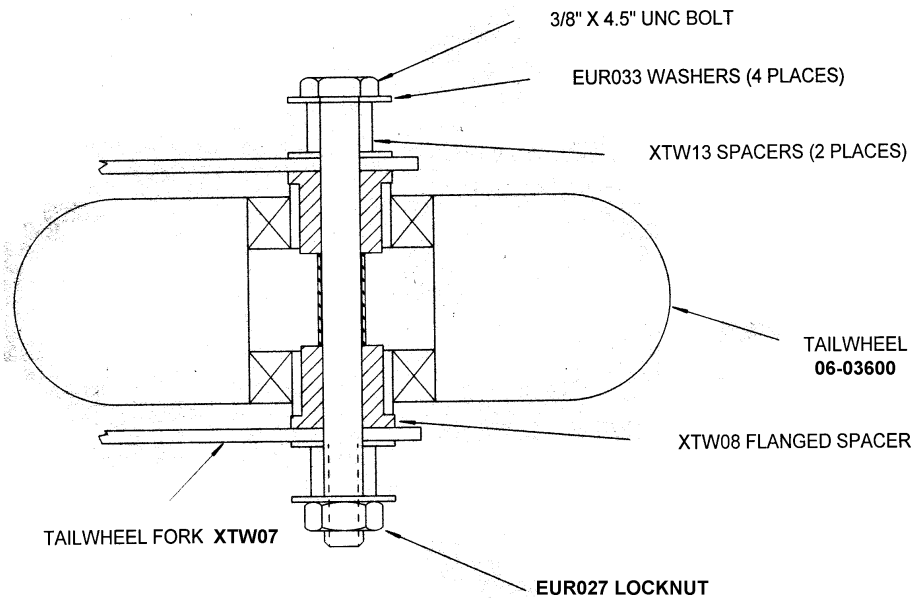

Fig 6. Section through tailwheel axle.

To space the tailwheel away from the sides of the fork spacers XTW08 are provided. Insert the spacers into the bearing hole each side and slide the tailwheel between the arms of the fork to line up the holes. The 3/8" x 4 1/2" bolt through the tailwheel should have on it at each end spacers XTW13 with EUR033 washers each side of them. These spacers provide a means with which to secure the tailwheel onto the trailer, and also for the attachment of a ground handling steering arm. Secure the bolt with a 3/8" Nyloc nut. See figure 6.

## Cables

Each rudder cable runs from the CS21 horn on the rudder pedal shaft, under a pulley and attaches to the rudder operating horn at the base of the rudder. The cable from the rudder pedals attaches above the horn, and the cable to the tailwheel is fastened below it. See figure 7.

### Port cable

The port cable will require a 1/4" hole in the rear bulkhead about 35 mm (1 3/8") to the port side of centre and a similar height from the floor as measured at the centre.

Make a simple fairlead from a short piece of the plastic cable sleeving supplied (Part no. BS116). This should be bonded in place once the exact run of the cable has been established - don't forget to slide it onto the cable before fitting the thimbles.

Another hole for the cable is required through the sternpost. Judge where this should be using the position of the cable attaching bolt on the horn as a guide.

Run the cable through both holes and adjust their positions as necessary for the cable to run in a straight line between pulley and operating horn. When the rudder is in its neutral position the hole through the sternpost will need to be opened up into a slot to allow for the sideways and vertical movement of the cable as the rudder moves through its range. The cable will pivot slightly at the rear bulkhead.

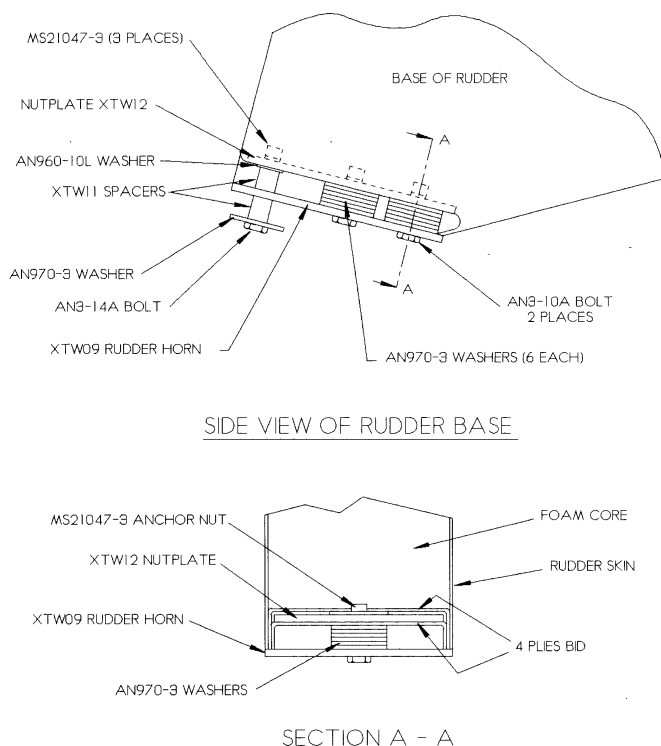

*Fig 7. Cable mountings.*



## Starboard cable

Cut a hole through the rear bulkhead for the cable at the same level as the port cable but within 2 cm (3/4") of the side wall.

The starboard cable will emerge through the fuselage side approximately 33 cm (13") forward of the rudder operating horn. Sighting through the access hole, and using the port cable also, judge the height at which the cable should run to maintain a horizontally straight line from the pulley to the horn and cut a small hole through. The cable will not be straight when viewed from above. The final hole will be a slot, wide enough for a fairlead made from a short piece of cable conduit to be bonded into.

## Rear thimbles

To establish the cable lengths, set both rudder pedals to their neutral positions where the uppermost tube of both pedals are in line with each other. Fix the pedals into this position ensuring they are unable to move. With the rudder straight, crimp on a thimble to each cable end so that it aligns with its horn attaching bolt. It's difficult to crimp cables to be an exact length so ensure that they are slightly longer rather than shorter. It's always possible to shorten the cable with an adjuster.

## Cables to tailwheel

The cables between the rudder horn and the tailwheel steering arm are made in two pieces which have a spring between them. The spring acts to take out shocks from the tailwheel.

Make up two cables 13 cm (5") long with AN100-C4 thimbles at each end using two 28-2-G Nicopress sleeves at each end to secure them. The cables should be measured as shown in figure 8.

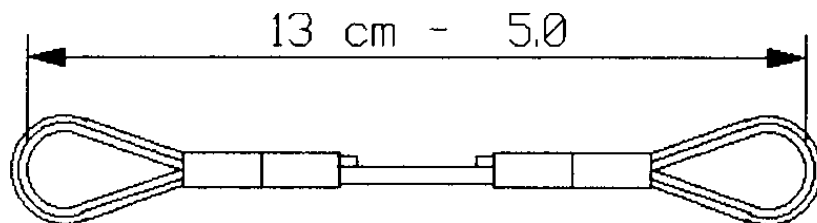

*Fig 8. Tailwheel drive cable.*

Hold the left rudder pedal back against its return spring, or disconnect the spring temporarily to enable the cable to be pulled aft easily. With the steel spacer XTW11 through the thimble of the cable install the AN3-14A bolt with an AN970-3 washer and another XTW11 steel spacer already on it into the left hole in the base of the rudder. Ensure also that one of the 13 cm (5") cables you previously made is attached to the lower portion of the bolt.

On the end of the horn protruding on the starboard side of the rudder attach the right rudder cable as detailed in figure 9.

Attach the second 13 cm long cable to the lower part of the attaching bolt in preparation for fitment to the tailwheel steering arm.

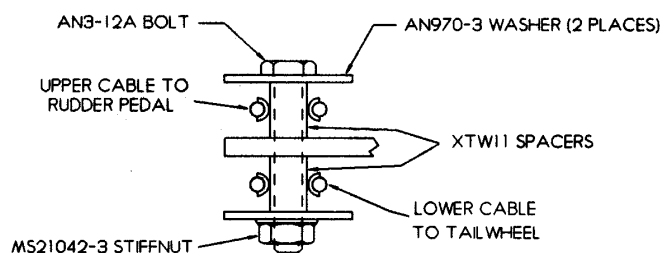

Fig 9. Detail of starboard cable fixing.

## Tailwheel steering cables

The length of these cables, which link the springs to the tailwheel steering arm, is determined by the amount of pre-compression of the springs. The springs should be pre-compressed approximately 10 mm when tailwheel and rudder are in their neutral position. The cables are connected to the tailwheel steering arm via steel wire rings. Install the rings to the two holes of the steering arm.

To install the springs into the short cables attached to the rudder horn, remove one spring hook from the spring, thread it through the thimble of the cable having first slid the spring and its remaining hook onto the cable. The axes of the two hooks should be at right angles, not parallel, to each other.

Now make up cables to run between the spring and the rings on the tailwheel steering arm such that the spring is compressed by  $10 \text{ mm} \pm 2 \text{ mm}$  from its relaxed length when the rudder and tailwheel are at neutral. Use two 28-2-G Nicopress sleeves to secure each thimble.

## Rudder stops

### Port rudder stop

The rudder is prevented from excess movement to port by the small protuberance on the port side of the rudder horn contacting the fuselage rear edge flange. In order to protect this flange from wear a reinforcing plate XTW14 must be fitted.

If necessary file the rear fuselage flange locally to obtain the necessary movement, which should be between  $30^\circ$  and  $32^\circ$ . Bond the reinforcing plate XTW14 to the inside of the port rear flange using Redux 420 so that its rear edge is flush with the rear fuselage flange.

### Starboard rudder stop

Movement to starboard is limited by the horn contacting a steel stop XTW10 mounted to the fuselage side just below the lower rudder hinge - see figure 10.

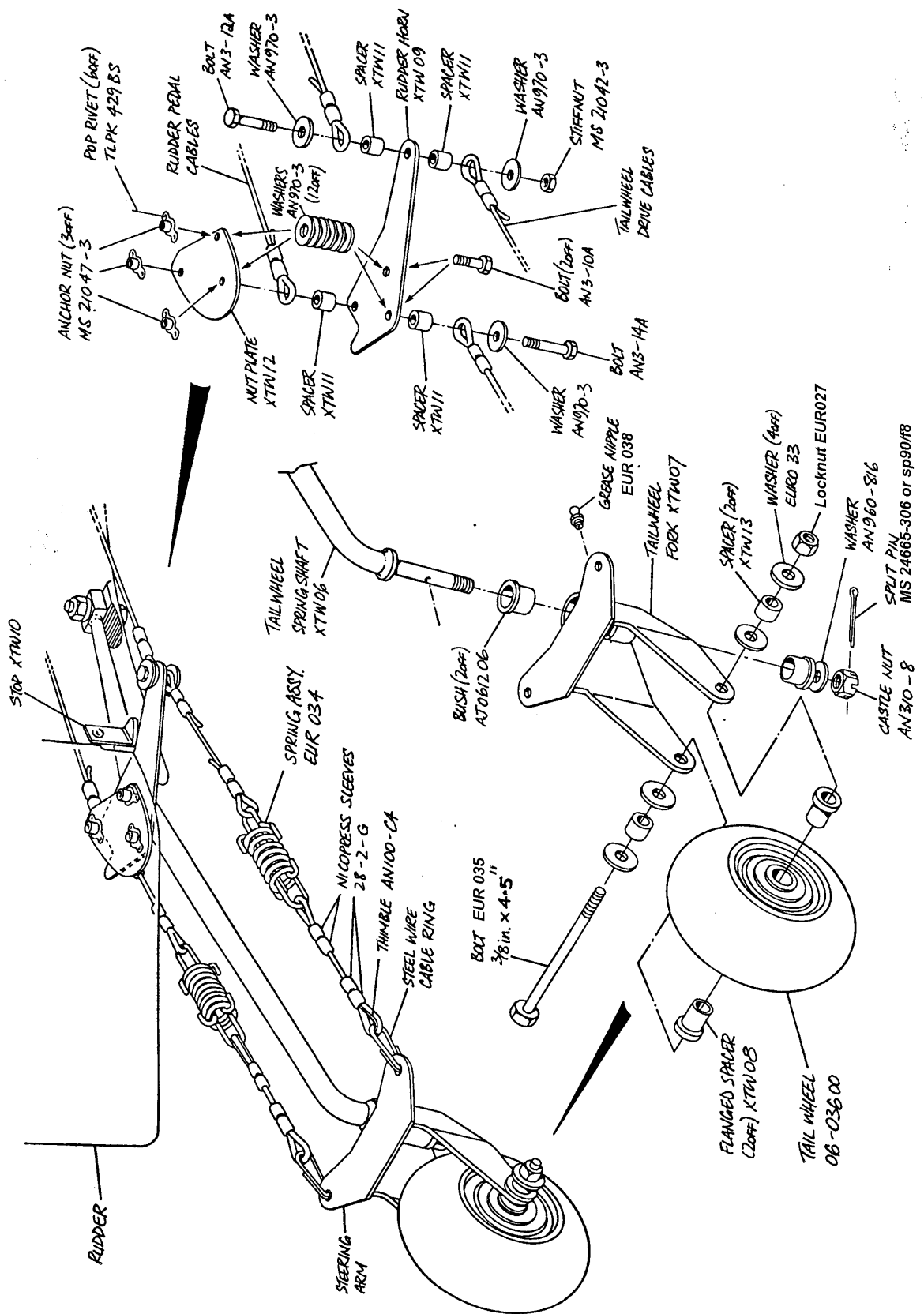

*Fig 10. Photo of starboard rudder stop.*

The protruding blade must be cut and filed to contact the rudder horn when the rudder reaches its maximum movement to starboard. The lowermost bolt fastening the hinge secures the top of the stop, and to facilitate variations in this position the upper hole in the stop has not been drilled.

Remove the lowermost rudder hinge bolt and set the rudder to be at 30° to 32° to starboard. With the stop XTW10 in position but with the oversized blade just underneath the rudder horn, mark a line on the blade where the horn front edge is. Cut and file the blade and, with it now aligned with the horn, drill through the flange and bolt the stop to it using an AN525-10R8 bolt and MS21042-3 nut with an AN970-3 washer under it.

Finally, drill through the upper part of the stop's flange where the hinge bolt hole is and secure the stop with the hinge bolt.





INTENTIONALLY BLANK