

## 22. Rudder system

Two pairs of rudder pedals are provided to enable full dual control capability. The shaft of one set will sit in front of the other, and the port side pedals are cranked forward to allow greater leg length. The general arrangement is shown in figure 1 at the end of this chapter. The pedals are connected, via cables guided by pulley wheels, to the rudder horn.

### Installation

Each set of rudder pedals is to be mounted in Tufnol bearings which are attached to a level glassfibre and plywood floor panel which will be bonded into the footwell.

#### Step 1

##### Floor panels

At the front of the cockpit module, at its junction with the firewall/footwell, is a vertical transverse flange. Cut pieces of 3mm plywood to make a horizontal floor for each footwell so that its rear-most edge lays on, and finishes flush with, the vertical flange of the cockpit module. The shape of the plywood floor panels will be curved on one side to match the curvature of the footwell. Trim the plywood to fit horizontally with the aircraft.

To support the inside edge and front of the floor panels, shape pieces of 25 mm (1") wide minimum scrap foam left over from the flying surfaces and place them in the footwell, bonding them in with dabs of dry micro. Layup 2 plies of 'bid' onto the underside of both floor panels and allow to cure before trimming. Temporarily position the floor panels in place and hold them with masking tape.

#### Step 2

Mark out hole centres for a slot to be made in the inside face of the starboard footwell to allow the rudder pedals through. See figure 2.

Take measurements square to the front face and underside of the footwell for the forward hole. As the front face of the port footwell is further forward by 45 mm, make sure that you allow for this when marking out the holes on that side.

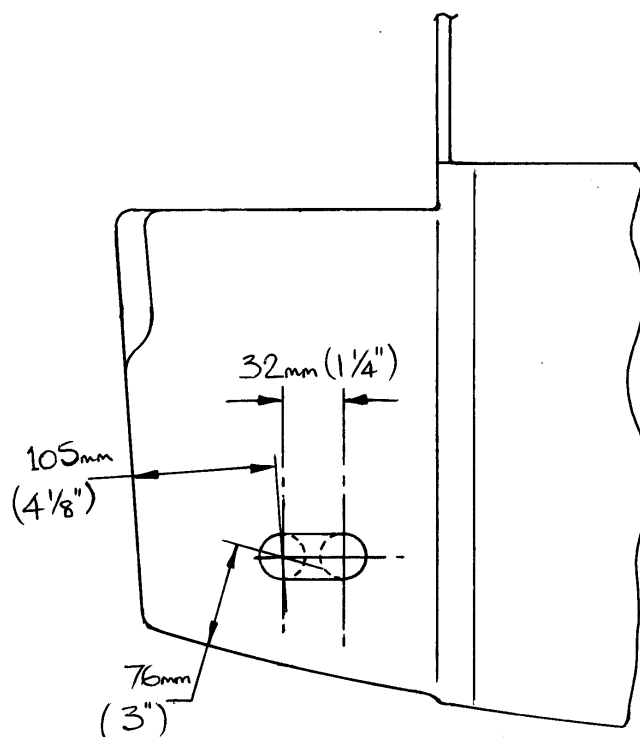

Fig 2. Slot for rudder pedals. Inboard face stbd footwell shown



Cut 30 mm diameter holes through the inside face of both footwells then join the two holes up to make a slot. Don't make these slots any bigger than you need to as this is also the firewall and any gaps will require sealing after the pedals are installed.

### Pedal reinforcement

Local reinforcement against buckling is required at the base of each rudder pedal arm. Short 5/8" diameter tubes are to be bonded within the horizontal shaft of each pedal.

### Step 3

Cut the 5/8" diameter steel tube CS31 into four equal length pieces of about 50 mm (2") long. Clean and abrade the outside surface of these tubes with coarse sand paper. Clean and abrade, as well as possible, the first 75 mm (3") of the bore of the pedal shaft where the pedal arms are welded to it. See figure 3.

Mix up some Redux 420 and flox and coat both the short tubes and the bore of the pedals, then insert the tubes into the pedals, positioning them as shown in figure 3, then leave to cure.

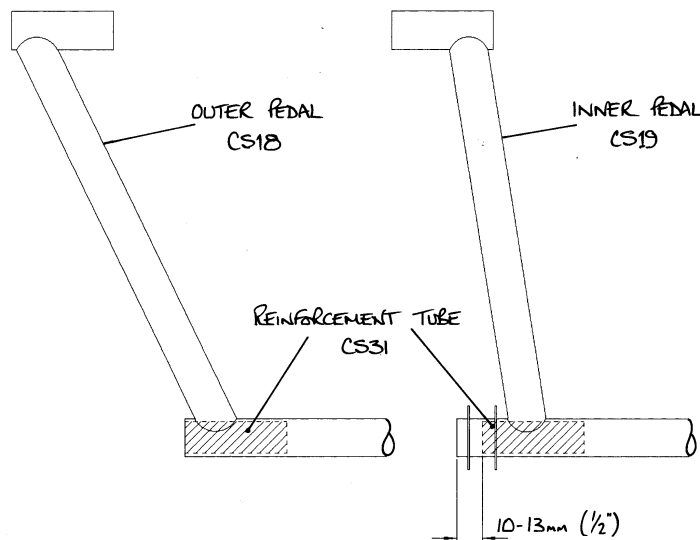

Fig 3. Rudder pedal tube reinforcement.

### Pedal installation

The two sets of rudder pedals, CS18/XCS19P and XCS18P/CS19, will be joined together with the flanges sandwiching a cable operating arm CS21. See figure 4 at the end of this chapter. Bolt both pairs together now to check that the shafts are in line. In the top hole in each CS21 insert the bolt, washers and spacers as shown in the inset diagram in figure 4 at the end of the chapter.

## Step 4

Before installing the rudder pedals, select the CS22 and CS23 Tufnol bearings and, referring to the figures at the end of this chapter, position them in pairs onto the rudder pedals and bolt them up. If the bearings are too tight, sand the bore of the bearing until the fit is correct. *Mark them in such a way as to identify their positions relative to each other and the rudder pedals themselves.*

Slide the two parts of the pedals through the slots in the sides of the footwells and bolt them together with a CS21 between the flanges of both pedals. Take one half of each of the CS22 and CS23 Tufnol bearing mounts and place them underneath the rudder pedal tubes to support them on the floor panels. Arrange the pedals' horizontal tubes to be square to the aircraft's centre line with the front of the forward pedals' tube on the starboard side being 90 mm (3 1/2") back from the inside front of the foot well.

## Pedal lateral alignment

### Step 5

Move the pedals sideways, without disturbing their fore and aft alignment, so that the inboard face of CS21 is 29 mm (1.14") outboard of the short tube oriented fore and aft in the landing gear mounting frame. See figure 4.

With the pedals set, drill through each of the Tufnol bearings into the plywood floor with a 4.8mm drill bit placing an AN3-20A bolt through each drilled hole to locate it before drilling the next. After drilling all the holes remove both floor panels.

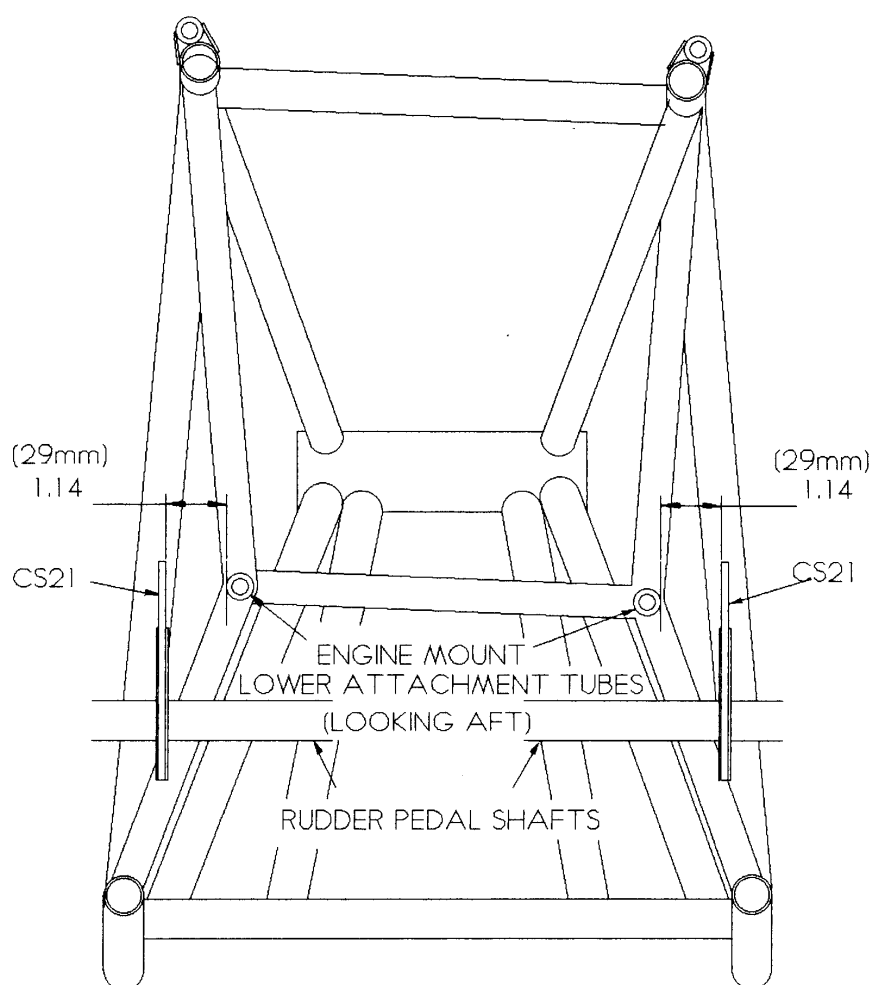

Fig. 4. Pedal lateral alignment (monowheel frame shown).



## Step 6

With an AN3-20A bolt through the holes in the floor panels attach an MS21047-3 anchor nut, finger tight, and hold it against the glassfibre underside. Drill through the anchor nut's lugs with a 3.3mm (1/8") drill and install them with TLPD419BS pop rivets. The rivets will pull through the wood and hold onto the glassfibre skin.

## Step 7

### Installing floor panels

Scuff sand the firewall around where the floor panel will meet it in preparation for bonding.

With blobs of dry micro on the foam supports, lay the floor panels in position, ensuring that they are on the same plane, and install the rudder pedals as before and bolt the bearings in place to align them correctly. See figure 7 at the end of this chapter.

Layup 2 plies of 'bid' at +/- 45°, to cover the floor and lap onto the firewall 5 cm (2") all around.

Run the cloth also from the floor and down the vertical section of cockpit module at the rear end of the floor panel and allow every thing to cure before disturbing them.

## Step 8

### Pulley installation

With an AN970-3 washer each side of the composite, push an AN3-13A bolt through the previously drilled holes in the lower rear of the cockpit module's centre tunnel, add three AN960-10 spacing washers, and slide on the AN210-2A pulley. The number of spacers may need changing later when the exact line of the rudder cable is established. Temporarily fasten the pulley in place with a plain 10-32 nut. Extra washers may be required to prevent the nut from bottoming on the thread.

## Step 9

### Cables

Make up one end of two cables with an AN100-C4 thimble and 28-2-G Nicopress sleeve. Tape up the loose ends of the cables to prevent them stabbing your fingers and to keep them tidy. Each cable should be left at least 445 cm (175") long. Slide the thimble onto the bolt and spacer on the rudder pedals' crank CS21 and run the cable, via the underside of the pulley, back to the rear fuselage. The other end of the cable will be finished after the tailwheel has been installed; for now it can simply be taped to the lower rear fuselage side.

## Cable adjustment

The pedals are set now for the maximum forward position. To shorten the cables' effective length, adjusters will be required.

The simplest and lightest method of shortening a cable, thus providing adjustment for different people, is to use two plates of light alloy with three nuts and bolts. See figure 5.

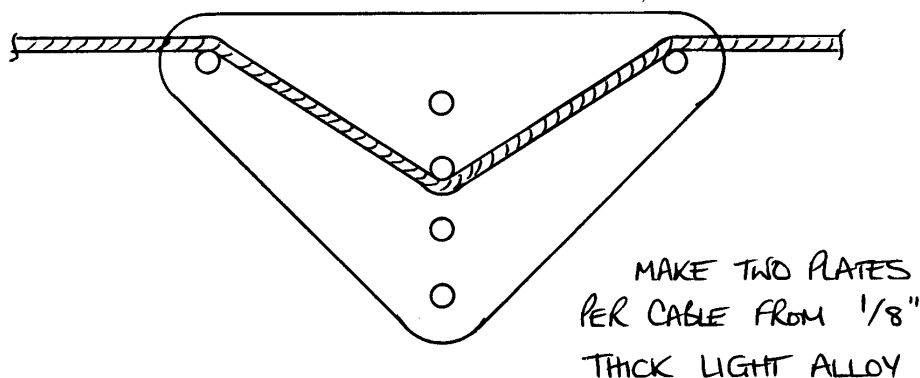

One of these adjusters would be required for each cable and will have to be located near to the tailwheel so there is sufficient clearance from the fuselage floor.

Alternatively, turnbuckles such as an AN140-16S or equivalent could be used. The following comprises one turnbuckle assembly of another suitable type:-

1 x MS21251-B3S	Barrel
1 x MS21255-3RS	Cable eye
1 x MS21255-3LS	Cable eye
2 x MS21256-1	Clip

You will also need two additional AN100-C4 thimbles and two 28-2-G Nicopress sleeves for each assembly.

### Step 10

#### Cable safety

To prevent the cable from slipping off the pulley, bond a piece of wood to the floor underneath the pulley such that it is close to the cable and will not allow it to slip out of the pulley's groove. Leaving this out could result in loss of directional control if the cable did come off the pulley. If the cable needs removal, the pulley will have to be loosened or removed.



## Step 11

### Cable tension springs

To keep the cable under slight tension and prevent the pedal falling backwards when not in use a spring (Part no. T 41780) is attached to each of the cranks CS21, the other end secured to a bolt at the front of the foot well. As the rudder pedals are set one in front of the other, the tension spring anchor points are also to be set one further forward than the other.

#### Aft pedals

On the starboard side drill a 4.8mm diameter hole through the side of the footwell as far forward as practical and on the same level as the top bolt through the crank. Push an AN3-7A bolt, with an AN970-3 washer under its head, through from inside the footwell then slide on an AN970-3 washer, an FL10 spacer and an AN960-10L washer and fasten them up with an MS21042-3 nut.

Hook the spring T41780 over the washer onto the spacer and attach the other end of the spring to the spacer OR9 at the top of CS21. Squeeze the eyes of the spring to prevent it from coming off.

#### Forward pedals

On the port side carry out the same procedure, again drilling the 4.8 mm hole as far forward as possible. The footwell front face is 45 mm (1.75") further forward on the port side than it is on the starboard side; this difference is similar to the gap between the pedal shafts, so the extension of the spring will be similar.

## Step 12

### Rudder cables in centre tunnel (monowheel)

To prevent the rudder cables snagging on the landing gear if the rudder pedals are moved aft individually or during retraction or extension Tufnol cable guides are added. One cable guide is used for each cable and diverts the cable slightly outboard adjacent to where the end of the swinging arm enters the wheel well.

The addition of the cable guide will cause the cable to contact, or be very close to the landing gear mounting frame so a Tufnol rubbing block is added immediately behind the frame.

## Cable guides and rubbing blocks

### Monowheel aircraft

Make two cable guides according to figure 6 using one of the 12 mm thick Tufnol blocks FL25. The slot depth should be as shallow as required to ensure the cable is clear of any part of the landing gear assembly.

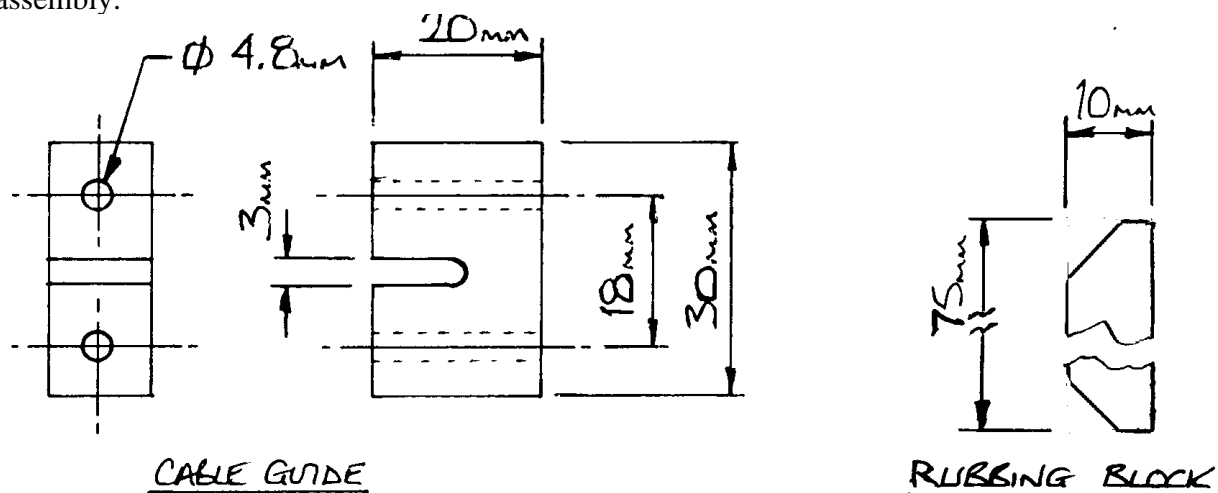

Fig 6. Cable guide and rubbing block.

### Installation of guides - monowheel aircraft

The cable guides are to be bolted to the plywood rib under the thigh supports. Firstly, establish the best position that the guide needs to be in to give maximum clearance. Fit the slotted cable guide by placing it so the slot engages the cable and push it outboard to contact the triangular rib of the thigh support in the correct fore and aft location. The guide should only be holding the cable outboard, not vertically in any direction.

Drill through the holes in the guide into the thigh support rib and install two AN3-12A bolts with MS21042-3 nuts and AN970-3 washers.

### All aircraft

Make also two cable rubbing blocks shown in the same figure.

### Rubbing blocks

Each rubbing block should be bonded to the inside of the wheel well immediately behind the vertical member of the landing gear mounting frame.



Cut the Tufnol rubbing blocks so that the cable is deflected away from, or not allowed to get closer than 2.5 mm (0.1") to, the landing gear mounting frame.

Round off or chamfer the ends so that the cable can't get caught on top or underneath. Do not add a guide which would restrict the cable's vertical movement as it travels fore and aft.

